

APPLICATIONS



Powerchairs / home mobility equipment
 Scooters, 3- and 4 wheels
 Cleaning Machines
 Lifts (stairs / bathrooms)
 Personal Carriers
 Utility Vehicles

SPECIFICATIONS



Nominal Voltage	12V	
Nominal capacity @20 hour rate	80Ah	
Capacity at 25°C	10 hour rate	70Ah
	5 hour rate	60Ah
	1 hour rate	42Ah
Shelf time @20°C up to 70%	in months	9
Internal resistance (at 1 KHz)	approx. 6 mΩ	
Operating temperature for (dis)charge	-15°C to + 40°C	

DIMENSIONS



Dimensions LxWxH (T) in mm	260x169x211 (215)
Weight	25kg (±2%)
Separator	AGM, Glass Mat
Case and cover	ABS
Terminal	M6 Bolt
Torque setting (recommended)	M6: 7 Nm
Maximum allowable torque value	M6: 9 Nm

CHARGING



Charging Voltage cycle use 14,4 to 15 Volt
 Float charge Voltage 13,5 to 13,8 Volt
 Charging current, minimum 7A - maximum 17A

CYCLE LIFE



To maximize the cycle life of the battery, we recommend to charge the battery fully after use. The total life of the battery, is very dependant on the correct charge and depth of discharge per cycle.

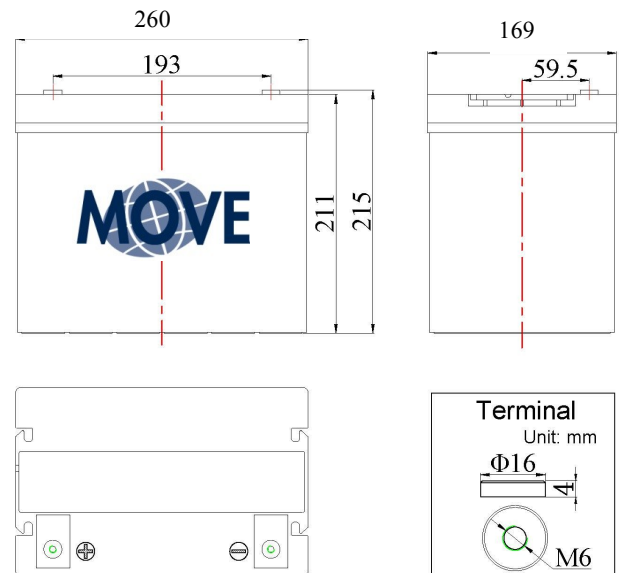

BATTERY LIFE UNDER CYCLIC USE

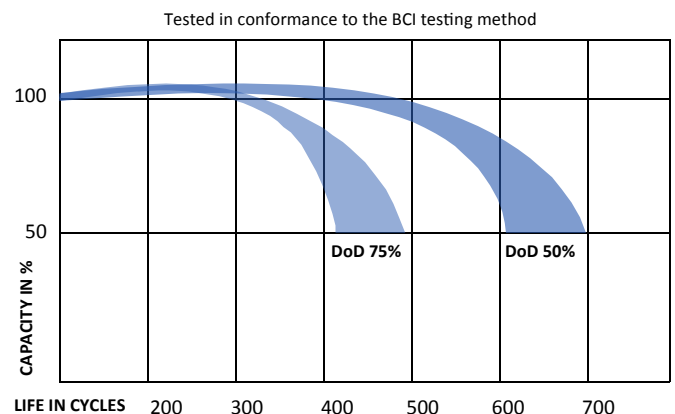

* Cycle life is measured with a discharge current 0,2C, charged 16h and rest capacity of 2/3 Cn